

SOLEAL NEXT

THE UNIVERSAL WINDOW

75 MM SYSTEM

Architect: Olympian Homes Ltd
Photographer: John Kees Photography



TECHNAL[®]

By  Hydro



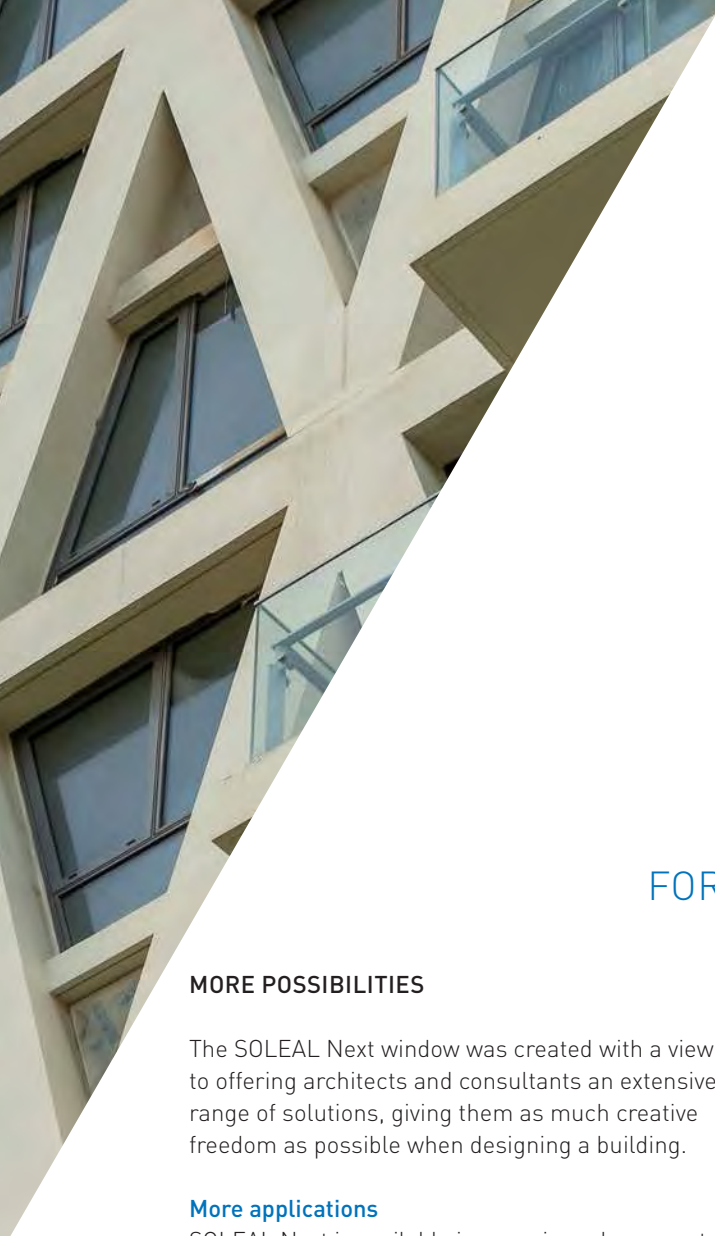

SOLEAL NEXT

/ THE UNIVERSAL WINDOW

WINDOW BEYOND LIMITS FOR THE ARCHITECTURAL CREATIVITY

MORE POSSIBILITIES

The SOLEAL Next window was created with a view to offering architects and consultants an extensive range of solutions, giving them as much creative freedom as possible when designing a building.

More applications

SOLEAL Next is available in open-in and open-out to adapt to all types of architectures. There are multiple applications: 1 and 2-leaves windows and patio windows, continuous horizontal windows, integrated or overlapping assemblies, fixed-light frames, with overpanel or side fixed lights, horizontal and vertical pivot frame and top-hung frame. .

The installation and cladding environments are the same as for SOLEAL Next doors and sliders.

More comfort

SOLEAL Next offers effective thermal, acoustic and weather tightness performances, complying with most international regulatory requirements.

More design

SOLEAL Next combines aesthetic design with a large choice of colours and accessories, as well as concealed elements, bringing elegance and modernity to new or renovated building projects.

LESS IMPACT

Using the UN Sustainability Goals as our compass, we aim to reduce by half our CO₂ emissions by 2025 and commit to contribute to quality education and capacity building for 500,000 people in our communities and for business partners from 2018 until the end of 2030.

Less CO₂ footprint

Using Hydro CIRCAL®, an alloy made with a minimum of 75% recycled end-of-life aluminium (post-consumer scrap), allows tons of scrap that would otherwise become solid waste to be reintroduced into the system. SOLEAL Next's thermal break elements are made from recycled material.

More recyclable

SOLEAL Next is under certification to obtain Cradle to Cradle® label. The specific characteristics contribute to constructing sustainable buildings that are eligible to be awarded to the main environmental certifications.

SOLEAL NEXT 75

/ MORE POSSIBILITIES. LESS IMPACT.

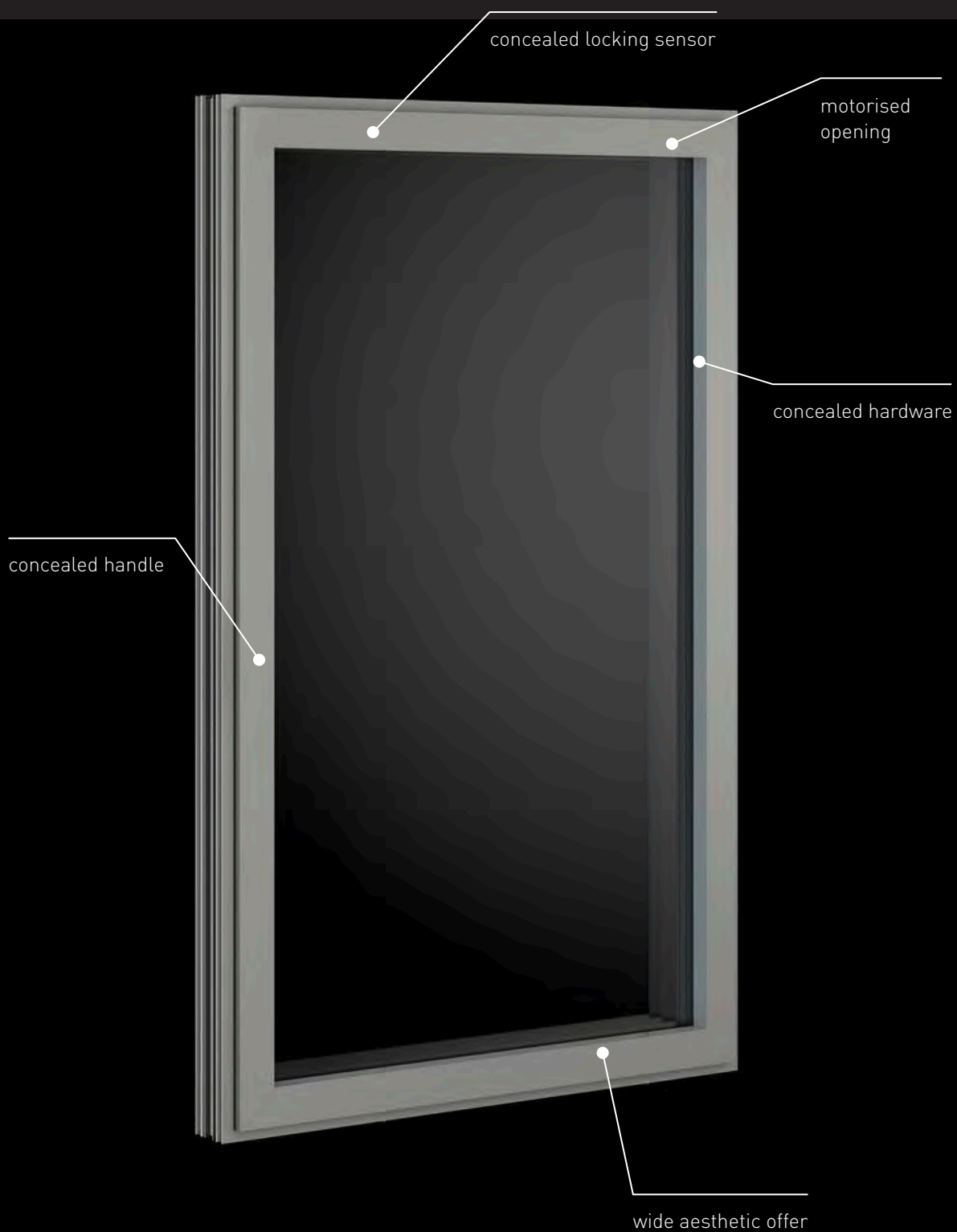

KEY FEATURES & INNOVATIONS

MORE DESIGN & AESTHETICS

- Wide choice of Visible vents and frames design
- Concealed hardware
- EXCLUSIVE® handle collection

LARGE DIMENSIONS

- Module: 75 mm
- Height: up to 3 meters
- Glazing thickness: up to 69 mm
- Infill weight: up to 160 kg

MORE APPLICATIONS

- Numerous opening possibilities
- Façade and other ranges integration
- Composite assemblies
- Residential door
- Motorised available for tilt
- Magnetic window contact

MORE SAFETY AND ACCESSIBILITY

- Burglary resistance up to RC3 and PAS24
- Security glazing beads for glass pane installation from the outside, including open-out
- Building management system: concealed locking sensor
- Antibacterial coating on handles
- Reduced threshold for disabled: 15-20 mm

MORE PERFORMANCES

- Thermal: U_w up to 0.79 W/m²K
- Air permeability: Class 4 (600pa)
- Watertightness: Class 1800pa
- Wind pressure resistance: Class 5 (2000pa)
- Acoustic performance: R_w up to 48 dB

MORE SUSTAINABILITY

- SOLEAL Next is made in Hydro CIRCAL®, aluminium made with a minimum of 75% recycled end-of-life aluminium.
- PVC-free components
- Cradle to Cradle®: under certification
- Dynamic EPD available on TechDesign
- 75% recycled and 95% recyclable

SOFTWARE

- Available in TechDesign
- BIM: available in Tech3D, Archicad and REVIT

SOLEAL NEXT

/ A MODULAR SOLUTION

VISIBLE OPEN-IN

The visible structure is balanced between the fixed frame and the opening vent, providing an additional aesthetical touch to the window.

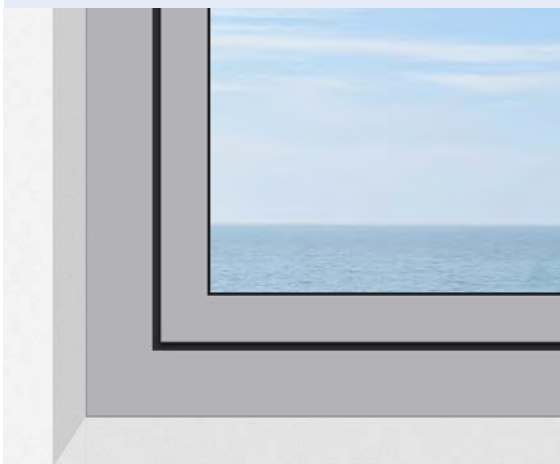
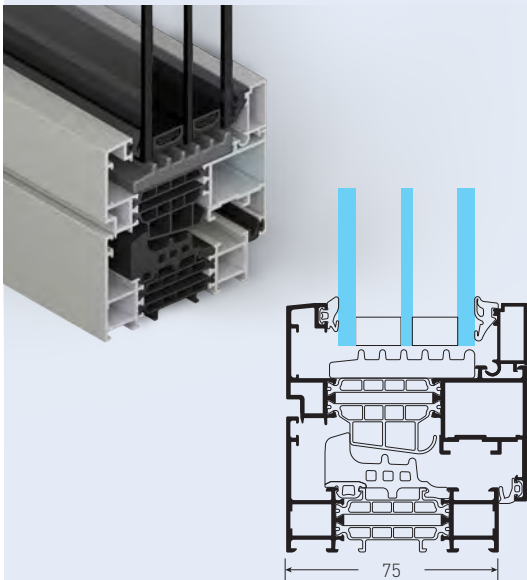

SOLEAL NEXT Visible Open-In

VISIBLE OPEN-OUT

Not only are there several designs of visible vents, it's also available for outward opening, giving a wide choice of possibilities.

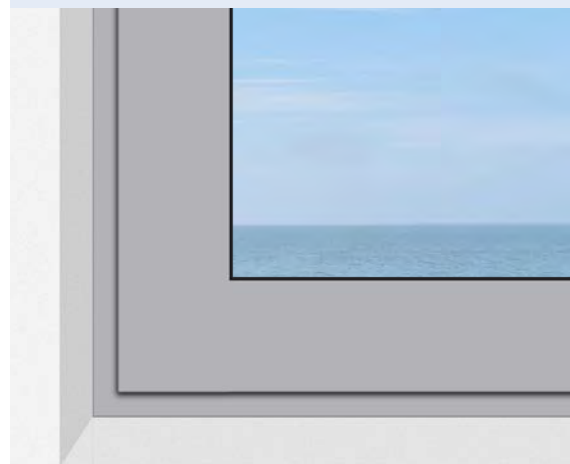
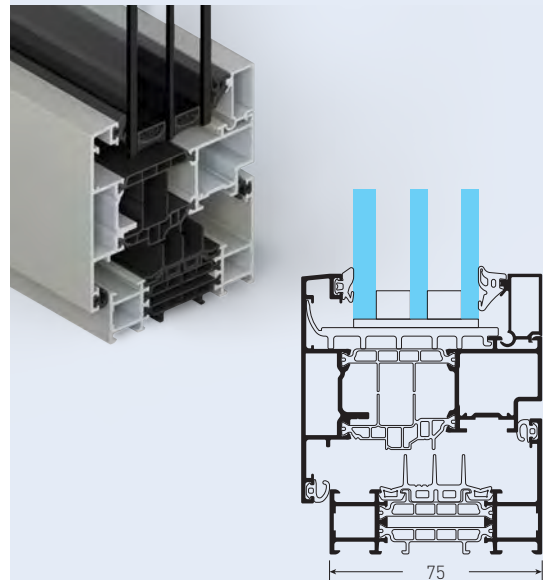

SOLEAL NEXT Visible Open-Out



SOLEAL NEXT

/ VISIBLE OPEN-IN

With a range of 5 different frames and 5 different vent designs, SOLEAL Next Visible can be offered in 25 different visual aspects.

FRAME DESIGNS

- Standard
- Step
- Slope
- Concealed drainage

VENT DESIGNS

- Square
- Step
- Slope
- Soft
- Flush

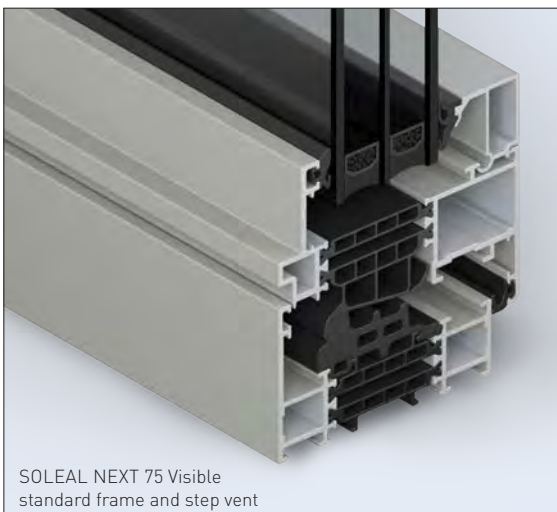
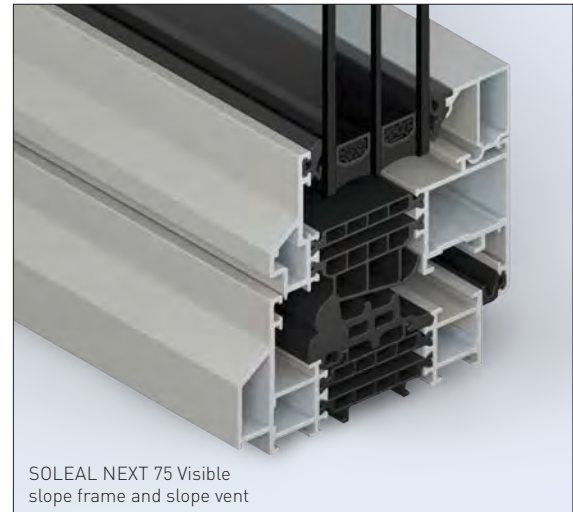
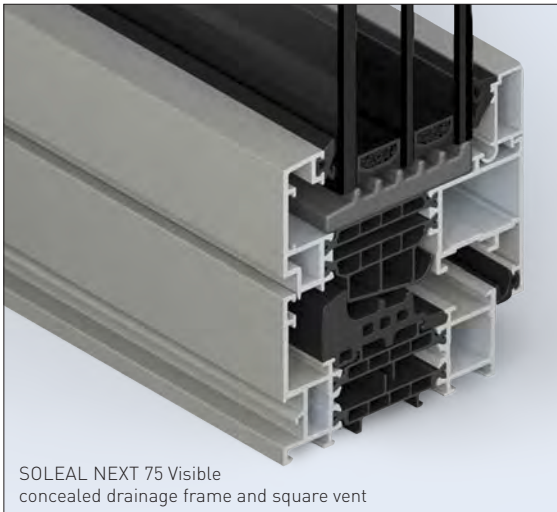

The stylish visible opening frame provides a contemporary, modern aesthetic.

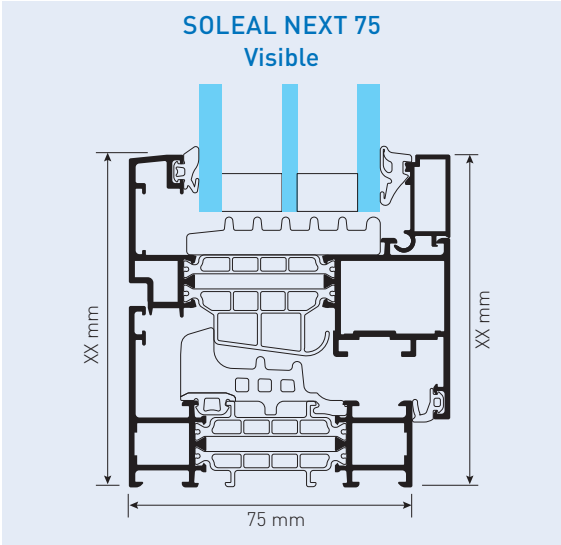

SOLEAL NEXT

/ VISIBLE OPEN-OUT

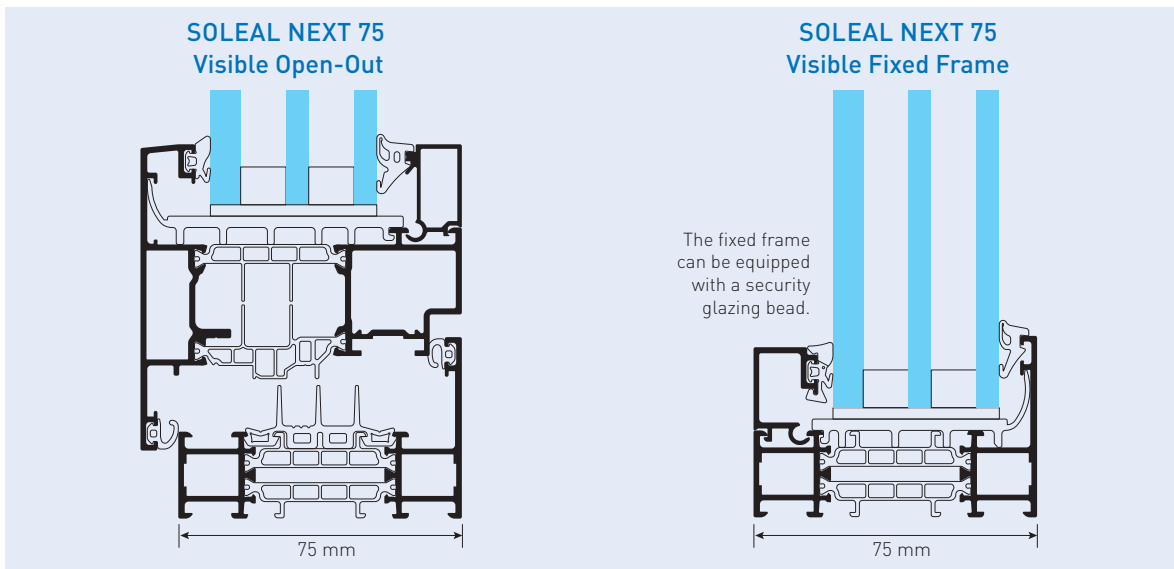

WINDOW FEATURES

- Vent optimized for friction stay (No packer on the vent)
- Straight cut central gasket (Overlapping lips)
- Exist in single and double vent
- PAS24 available

RESIDENTIAL DOOR FEATURES

- Door lock offer
- Door hinges tested at 200 000 cycles

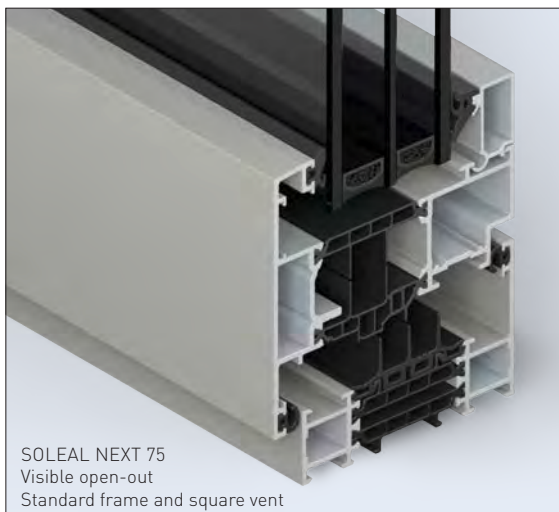



SOLEAL NEXT

/ CONCEALED ELEMENTS AND HARDWARE

AESTHETICS

- Concealed hinges to create a minimalistic look
- Thin hardware components, harmonious finishes
- Finishing covers tie rod and frame groove for a clean appearance

FAST ASSEMBLY

- Frontal mounted elements
- Direct punching of the tie rod
- No groove notching on the vent
- Positioning with breakable stoppers

SIMPLE SUPPLY

- No coated or anodized part, which reduces lead time for supply
- All components are common except for the bottom hinge, which enables stock to be built up according to weight and opening

LARGE DIMENSIONS

- Up to 3 m height
- 160 kg per vent

COMPREHENSIVE SOLUTION

- Bottom hinges adapted to the weight of the glazing and the type of project:

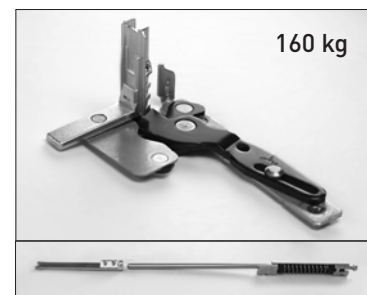
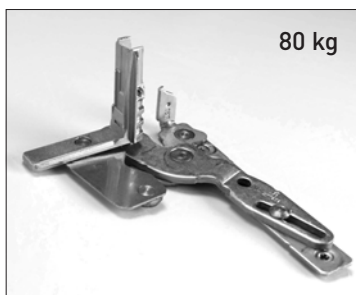

CONCEALED DRAINAGE

Concealed, our drainage is strategically placed on the casement frame to drain water out while preventing the air from coming inside.

If visible, our minimalistic drainage cap features standard colour, or lacquered in order to match the tint of the window.

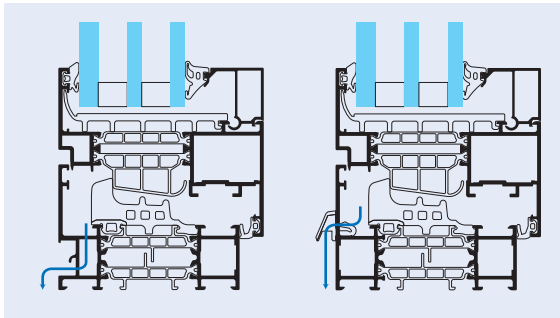

Concealed drainage versus traditional drainage through the frame profile and drainage caps

CONCEALED LOCKING SENSOR

The concealed locking sensor is integrated into the profile. It represents an additional security features as it sends an alert on the user's device when the window is not properly closed. It's easy to mount, and without any maintenance operation (no battery).



Architect: Elding Oscarsson Architects
Photographer: Erik Wik

SOLEAL NEXT

/ MORE AESTHETIC FEATURES

2 VENTS MULLION SOLUTIONS



REDUCED SIGHTLINE

- 146 mm for Visible vent with add-on rebate
- 116 mm for Minimal vent

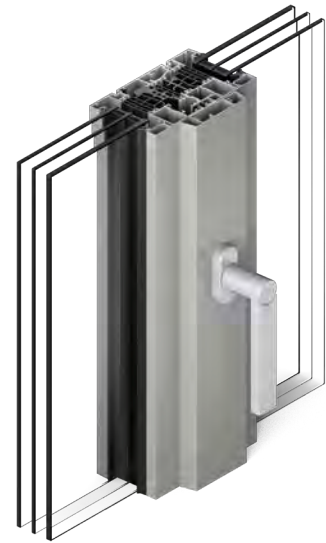

CENTERED HANDLE

- Contributes to an harmonious internal design
- Available in Minimal and Visible vent

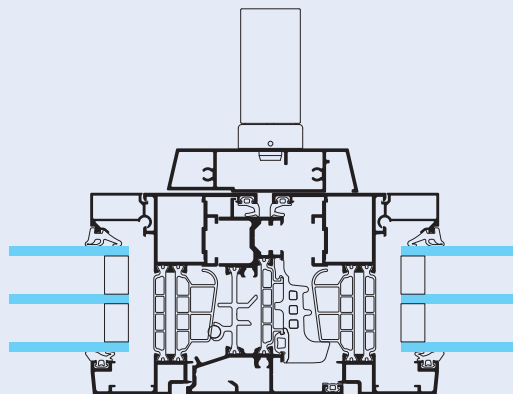

SOLEAL NEXT Visible



SOLEAL NEXT

/ EXCLUSIVE® HANDLES COLLECTION

The discreet but effective design approach for our new EXCLUSIVE® range - SELECTION, TEMPTATION & PASSION - aims to allow users to customise their handles, creating a sophisticated but timeless and functional visual signature on SOLEAL Next windows. Our handles offer a wide choice of colours, noble materials and clean lines.



/ SELECTION

True to TECHNAL's practical approach to design, this range of handles draws attention with its understated and elegant lines. A strong visual identity with simple and graphic geometric shapes, round or square, with an ergonomic design to the touch that modernises the current offer. Proven quality, with anodised or coated finishes for each handle, not to mention the new black anodised finish that adds an extra level of sophistication.



/ TEMPTATION

This range builds on TECHNAL's expertise, taking its extruded aluminium design to new levels of high quality and clean lines. All the elements come in a mix of finishes, textures and colours and can be combined to get unique and personalised colour options. All this designed to achieve a unique visual sensation and a magnificent experience to the touch.

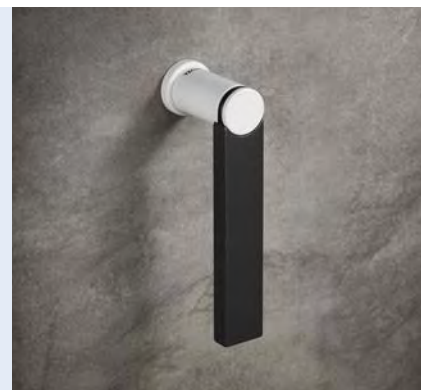

/ PASSION

Taking design to new heights, the passion range is a new expression in luxury fittings, with exclusive mixes of finishes and materials aimed at pleasing even the most demanding users. Making use of simple geometric shapes, this collection works as the perfect complement to a wide range of architectural aesthetics.



ROUND AND
SQUARED HANDLES
WITH STANDARD ROSETTES



ROUND AND
SQUARED HANDLES
WITH REDUCED ROSETTES



HANDLES
WITH
LOCKS





SOLEAL NEXT 75
Visible Open-Out



APPLICATIONS 75 MM MODULE

OPEN-IN



Fixed frame

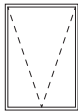

Bottom-hung

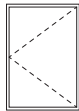

1 leaf

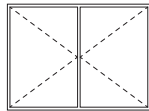

2 leaves

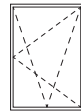

Turn/tilt or
tilt/turn 1 leaf

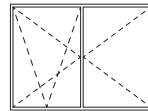

Turn/tilt or tilt/turn
2 leaves

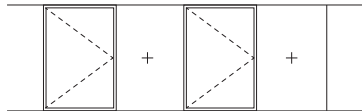

Ribbon window

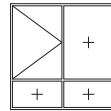

Fixed composite
open-in window

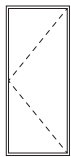

Residential door with
threshold 1 leaf

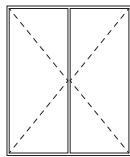

Residential door with
threshold 2 leaves

OPEN-OUT

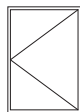

Side-hung
1 leaf

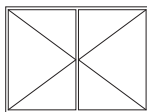

Side-hung
2 leaves

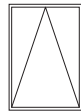

Top-hung

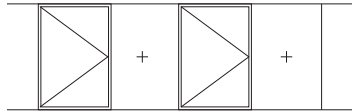

Ribbon window

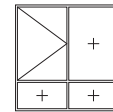

Fixed composite

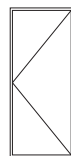

Residential door
with threshold
1 leaf

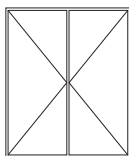

Residential door
with threshold
2 leaves

SOLEAL NEXT

/ RESIDENTIAL DOOR

2 BOTTOM SECTION OPTIONS

- Features no threshold with lowering gasket
- One low threshold profile to allow easy entrance for disabled

ENDURANCE

- Door hinges tested: 200.000 cycles

APPLICATIONS

- Single and double residential door open-in
- Single and double residential door open-out

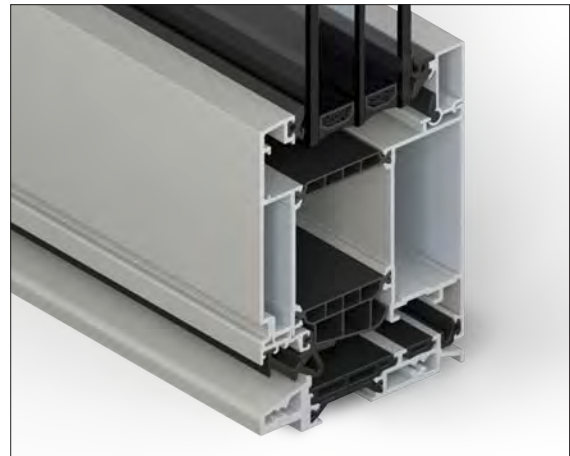

/ MORE ACCESSIBILITY

FIXED FRAME THRESHOLD FOR DISABLED

- Adapted for easy access on all available applications:
 - Easy opening / closing
 - Adaptable handle height
- No functional gasket at bottom
- No front drainage like flush doors
- Sloped < 5mm
- 15 mm and 20 mm solution can be used with support profile

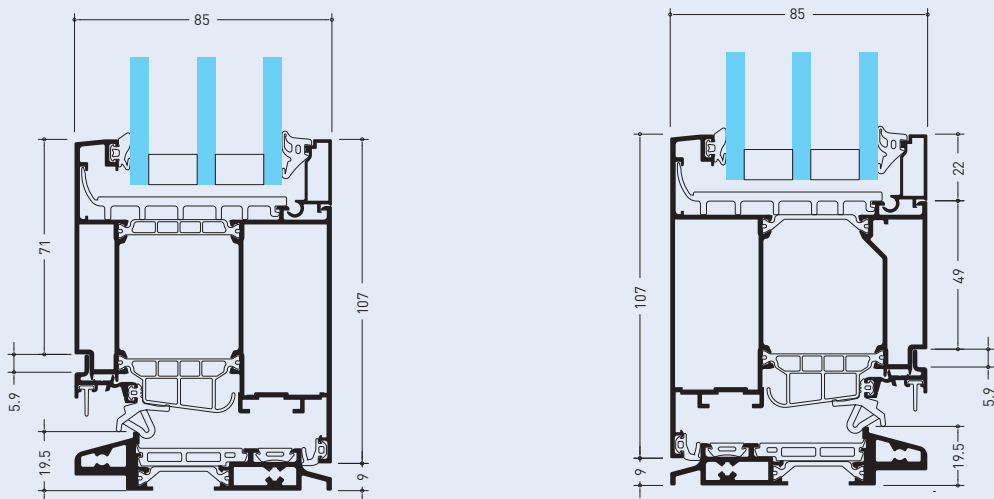

SOLEAL NEXT

/ MORE SAFETY

BURGLARY RESISTANCE

SOLEAL Next provides excellent protection against burglary, up to Resistance Class 3 (RC3) in accordance with EN-1627-30 and PAS24. It can be fitted with multi-point locks as an optional feature. Locking handles are available to increase security and reduce the risk of burglary.

APPLICATIONS

RC3 available for the following window types:

- Fixed frame
- 1 leaf turn
- 1 leaf turn & tilt

PAS 24 available for the following window types:

- Side hung 1 leaf and 2 leaves
- Top hung friction hinges open-out
- 1 leaf turn & tilt open-in and tilt before turn

MOTORISED OPENING CONTROL TO REDUCE ENERGY LOSS

- Available for tilt open-in
- Simple solution, easy to install
- Concealed chain engine
- 1 or 2 chain drive depending on configuration
- High tightness performances
- Locking sensor optional
- Silent operation system; less than 35 dB
- Suitable for building management system
- 2 year guarantee



Motorisation can be integrated in SOLEAL Next Visible vent, tilt open-in, in both 65 and 75 modules.

SOLEAL NEXT

/ MORE THERMAL MODULARITY

Our modular design allows to cover several thermal performance levels, from hot temperature regions to the coldest parts of the world.

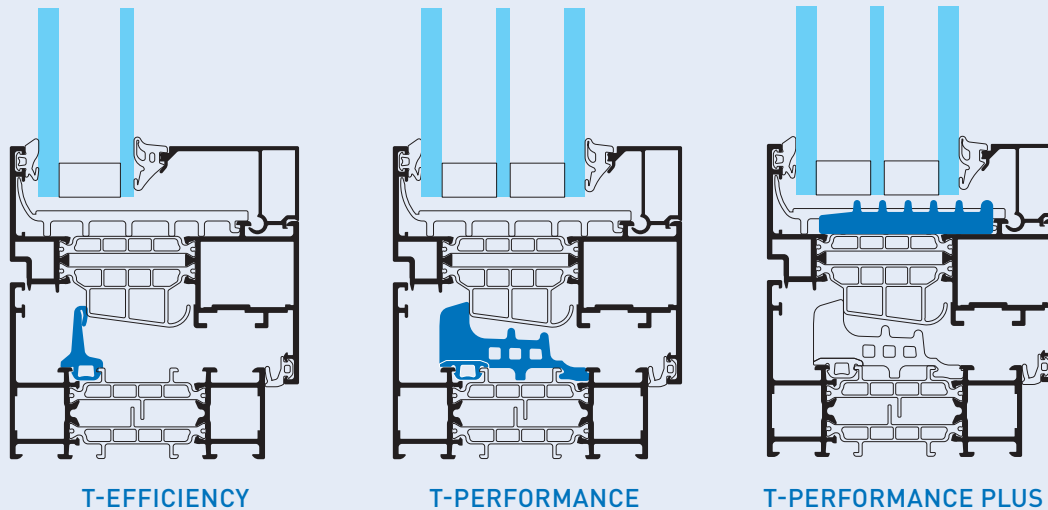

WEATHER PERFORMANCES - WITH CONCEALED HARDWARE

Application	W x H (mm)	Air tightness	Water tightness	Wind resistance
Visible Open-In 75 mm, 1 vent tilt&turn	1500 x 1700	A4	1500	C5
Visible Open-Out 75 mm, 2 vents hinged	1820 x 840	A4	1650	C4
Visible Open-Out 75 mm, top-hung, friction stay	1844 x 1844	A4	1650	C5
Visible Open-Out 75 mm, 1 vent side-hung	884 x 1844	A4	1500	C5
Visible Open-Out 75 mm, 2 vents side-hung	1650 x 1844	A4	1350	C5

THERMAL PERFORMANCES - SOLEAL NEXT 75

Application	Dimensions W x H	U _g	Warm Edge Swisspacer Ultimate				
			spacer	glazing	24 mm	24 mm	28 mm
SOLEAL NEXT Visible Open-In 75 mm							
window, 1 vent	1230 x 1480	U _w =	1.3	1.2	1.2	1.0	0.79
residential door, 1 vent	1230 x 2180	U _w =	1.3	1.2	1.2	0.92	0.79
window, 2 vents	1530 x 1480	U _w =	1.3	1.3	1.2	1.0	0.86
residential door, 2 vents	1530 x 2180	U _w =	1.3	1.2	1.2	1.0	0.83
SOLEAL NEXT Visible Open-Out 75 mm							
window, 1 vent	1230 x 1480	U _w =	1.3	1.2	1.2	1.0	0.85
residential door, 1 vent	1230 x 2180	U _w =	1.3	1.2	1.2	1.0	0.81
window, 2 vents	1530 x 1480	U _w =	1.4	1.3	1.3	1.1	0.92

SOLEAL NEXT

/ COMMITMENT AND SUSTAINABILITY

TECHNAL demonstrates its strong commitment to the environment in all areas: by using recycled and low-carbon materials, with a product design that is adapted to a circular economy, and produced within a responsible supply chain. In addition, these statements are certified by external organisations to ensure maximum transparency.

HYDRO CIRCAL®

We are demonstrating our focus on sustainability by using Hydro CIRCAL® for our system solutions, one of the most sustainable aluminium alloys in our sector. Hydro CIRCAL® is a range of prime quality aluminium made with a minimum of 75% recycled end-of-life aluminium (post-consumer scrap). The production process is verified by an independent third party (DNV-GL), and confirmed by an EPD (Environmental Product Declaration). Hydro CIRCAL® also has **one of the smallest CO₂ footprint worldwide: 2.3 kg CO₂ per kilo of aluminium** – 4.5 times less than the world global primary average.

RECYCLED & RECYCLABLE

Following our path to the certified circular economy, all of our systems are composed with a majority of materials and components that can be infinitely recyclable, that can come from recycled raw materials, that can be recycled to have a second life or components that can also be reused.

In rough figures, we're talking about **75% recycled content and 95% recyclable content**. It's an efficient way to drastically reduce the impact of materials on the life cycle of a building. Finally, our greener approach goes a step further thanks to recycled thermal strips for 75 mm modules.

75% RECYCLED POST CONSUMER

Hydro CIRCAL® is the world's first certified recycled aluminium which means that at least 75% of the prime-quality aluminium alloy comes from post-consumer materials.

95% ENERGY SAVED

By recycling post-consumer scrap aluminium, the remelting process saves up to 95% of energy that would normally be spent and maintain the same high quality as primary aluminium.

85% REDUCTION OF CO₂ EMISSIONS

The consequence of using Hydro CIRCAL® is the drastic reduction in CO₂ emissions which sums more than 85% when compared with the global average for primary aluminium production.

SOLEAL NEXT
75% RECYCLED
95% RECYCLABLE



SOLEAL NEXT

/ CERTIFICATIONS



CRADLE TO CRADLE (C2C) CERTIFICATION

From its design to the selection of materials and how it is manufactured, the product must offer the level of performance required by the market by reducing, to the greatest extent possible, environmental impacts such as energy consumption or greenhouse gas emissions.

We classify our range under the criteria of the Cradle to Cradle seal, an independent institute that certifies products and processes from a circular economy perspective. We have numerous Cradle to Cradle certified series, including the manufacturing in our plants. In this way, we are able to ensure that the carbon footprint of transporting our products is as low as possible.

Our range is under certification.



ALUMINIUM STEWARD INITIATIVE (ASI)

ASI is a multi-stakeholder, non-profit, standards-setting and certification organisation. It is the most internationally recognised standard, which addresses the environmental, social and governance (ESG) aspects of the entire aluminium value chain. The assessment is based around the sustainable production of aluminium, from bauxite or mining to the production of semi-fabricated products, taking into account the recycling of pre- and post-consumer scrap. Hydro was one of the first companies, that received this recognition, in accordance with its commitment to a more sustainable future.

100% of our extrusion plants are ASI Performance Standard Certified.



ENVIRONMENTAL PRODUCT DECLARATION

An Environmental Product Declaration (EPD) is an independently third party-verified document that communicates precise, transparent and comparable information about the life-cycle environmental impacts of a product. But it is not only limited to products, such as a window, but can also be applied to materials (an aluminium billet), assembly parts of products or even for services (like maintenance). This document is used for many different applications, e.g. public procurement or green building rating schemes (i.e. BREEAM, LEED, DGNB).

Thanks to our software TechDesign, it's possible to generate a dynamic EPD according specified dimensions, applications any type of glazing.





IMAGINE WHAT'S NEXT

Head Office
Severn Drive, Tewkesbury
Gloucestershire
GL20 8SF

Tel +44 1684 853500

Northern Office
Cedar Court Office Park,
Denby Dale Road, Wakefield
WF4 3FU

info.uk@technal.com

London Office
The Building Centre
26 Store Street, London
WC1E 7BT

www.technal.co.uk